

CAMWorks provides a programming solution for milling and turning in the same machine tool. Mill-turn machines are capable of performing turning and milling operations in a single setup that can reduce part handling and increase production.

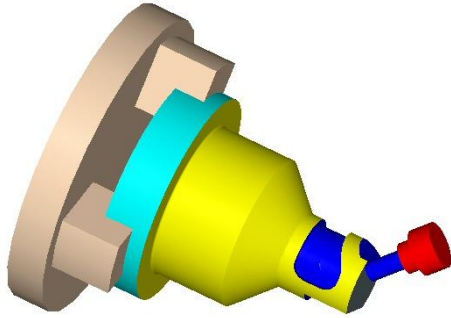

## Mill Features

- Mill features, identified by Automatic Feature Recognition (AFR) and defined using Interactive Feature Recognition (IFR), are supported for Y axis milling on the OD and the Face of the part. For more details on Mill features, see the CAMWorks 2½ Axis Mill data sheet.
- 3-Axis features can be defined interactively for Y-axis milling.

## Wrapped Features

- Interactively defined Wrapped features are cylindrical in shape and are cut by controlling the Z and C axis.
- Support for wrapped pocket, slot, boss and open profile features on OD of the part.
- Wrapped features can be defined by picking cylindrical edges, faces or loops from the solid model.
- Wrapped features can also be defined from 2D sketches by specifying a wrapping diameter.
- Solid model cylindrical faces or edges can be unwrapped to 2D sketches that can be modified and used to create Wrapped Features.
- Option to compute wrapped toolpath at either top or bottom of the feature.
- Operations performed on Wrapped features can have user-defined contain and avoid areas.



## Turn Features

Turn features on the OD or ID of the part, front face and grooves are found by AFR or inserted interactively using IFR. For more details on Turn features, see the CAMWorks Turning data sheet.

## Operations

- For Mill features, 2½ Axis, 3 Axis and 4/5 Axis simultaneous Mill operations are generated (depending on the Mill module). These include automatic roughing, finishing, thread milling and single point (drilling, boring, reaming, tapping) cycles and all 3 Axis cycles. All machining operations are defined, calculated and verified in the SolidWorks environment.
- Turning operations include automatic roughing, finishing, grooving, threading, cutoff and single point (drilling, boring, reaming and tapping) cycles.
- Toolpath simulation shows motion of rotational and linear axes.
- Option to override 4th or 5th axis prepositioning angle when necessary for some machines and conditions.



## C, Y and B Axis Machining

Machining cycles are available for C, Y and B axis machining at compound angles and on the Face, ID and OD of a part. Supported mill tool axis motion:

### C-Axis OD

- Generates wrapped toolpath on a cylinder about the turning axis (Z). Z and C axes are controlled simultaneously while tool stays on centerline of part.

### Y-Axis OD

- 3 Axis Milling: X,Y,Z simultaneous cutting.

### B Axis OD

- Toolpath is generated on a fixed C & B axes position.
- 2½ Axis Milling: tool moves to depth in one axis with simultaneous cutting in other axes.
- 3 Axis Milling: XYZ simultaneous cutting.

### Face Milling

- For 2½ Axis Milling: tool positions to depth in Z with X,Y simultaneous or X,C simultaneous cutting.
- 3 Axis Milling: XYZ simultaneous cutting.

### 4/5 Axis

- Full 4 and 5 axis milling.

## CAMWorks Modules

CAMWorks modules are available in a variety of bundles or combinations:

- 2 ½ Axis, 3 Axis, 3 Axis with undercut
- 4 Axis and 5 Axis Simultaneous milling
- 2 and 4 Axis Turning
- Rotary Milling
- 2 and 4 Axis Wire EDM
- ElectroWorks™ 
- Volumill™



**Geometric Technologies**  
15974 N. 77<sup>th</sup> Street # 103  
Scottsdale, AZ USA 85260  
[www.camworks.com](http://www.camworks.com)

**Authorized Reseller**